

Sit back. Relax. Stay warm.



Outdoor Patio Heater

Item # : LIP-10-TGG-HS, L10-SS-PP, L10-SS-P 304,
PH-S-112-MK, L10-SS-BK P, L10-SS-BK 304, L10-
SS-BR P , PH-S-112-GY
Model # : KLD7002S



DANGER

FOR YOUR SAFETY:

If you smell gas:

1. Shut off gas to the appliance.
2. Extinguish any open flame.
3. If odour continues, keep away from the appliance and immediately call your gas supplier or fire department.

WARNING

Do not store or use gasoline or other flammable vapors and liquids in the vicinity of this or any other appliance. An LP-cylinder not connected for use shall not be stored in the vicinity of this or any other appliance.

DANGER

DANGER indicates an imminently hazardous situation which, if not avoided, will result in death or serious injury.

WARNING

Improper installation, adjustment, alteration, service or maintenance can cause property damage, injury or death. Read the installation, operation and maintenance instructions thoroughly before installing or servicing this equipment.

DANGER

Failure to comply with the precautions and instructions provided with this heater can result in death, serious bodily injury and property loss or damage from hazards of fire, explosion, burn, asphyxiation, and/or carbon monoxide poisoning. Only persons who can understand and follow the instructions should use or service this heater.

WARNING

FOR OUTDOOR USE ONLY!

WARNING

This product can expose you to chemicals including carbon monoxide which is known to the State of California to cause birth defects or other reproductive harm. For more information go to www.P65Warnings.ca.gov.



ATTACH YOUR RECEIPT HERE

Keep a copy of your proof of purchase or order confirmation which will be needed if you need to contact us about warranty coverage.

Serial No. _____

Purchase Date _____

NOTE: 1 "AAA" battery (not included) is required for the electronic igniter.



Questions, problems, missing parts?

Before returning to your retailer, our exceptional customer service is available.

Call us toll-free at (800) 561-5550- Friday 7:30 a.m. - 4 p.m., PST, email us at customercare@jrhome.com

TABLE OF CONTENTS

Before You Begin	Page 2
General Description	Page 3
Safety Information	Page 4
Package Contents	Page 5
Hardware Contents	Page 5
Assembly	Page 6-9
Operating Instructions	Page 10-13
Care and Maintenance	Page 14
Troubleshooting	Page 15
Warranty	Page 16



BEFORE YOU BEGIN

Please read and understand this entire manual before attempting to assemble, operate or install this appliance. If you have any questions regarding the product, please call us toll-free at **(800) 561-5550 Monday – Friday, 7:30 a.m. – 4 p.m., PST**, email us at customercare@jrhome.com

This manual contains important information about the assembly, operation and maintenance of this patio heater. General safety information is presented in the first few pages and is also located throughout this manual. Keep this manual for future reference and to educate new users of this appliance. This manual should be read in conjunction with the labeling on the appliance. Safety precautions are essential when any mechanical or propane fuelled equipment is involved. These precautions are necessary when using, storing, and servicing. Using this appliance with the respect and caution demanded will reduce the possibilities of personal injury or property damage. The following symbols shown on page 3 are used extensively throughout this manual. Always heed these precautions, as they are essential when using any mechanical or propane fueled equipment.

GENERAL DESCRIPTION



This appliance is a propane transportable heater. The burner is controlled and adjusted by the gas control knob. Gas supply is controlled by the valve on the gas cylinder.

The burner is made of stainless steel, heat diffusion is assisted by the reflector above.

Technical specifications :

Operating pressure with gas	: 11 in. WC/27.9cm (water column) (2.75 Kpa)
Inlet gas supply pressure	: Min. 5 psi, Max. - 150 psi
Max. Heat rating	: BTU 46,000
Low setting rating	: BTU 25,000
Radiant Heat Range	: 14 ft./4.27m To 16ft./4.88m Diameter
Fuel Type	: Liquid Propane Gas
Cylinder Size	: Standard Industry 20lb./9.07kg Cylinder (5 gal./18.9 L Cylinder capacity)
Consumption Rate	: Approx. 10 hrs. at highest setting
Gross Weight	: 60 lb./27.21 kg
Certifications	: ETL
Gas Pressure Water Column	: 11 in./27.9cm (2.75Kpa)
Main Orifice Diameter in mm	: 1.8

MADE IN CHINA



**** WARNING ****

Improper operation, installation, adjustment, alteration, servicing or maintenance can cause severe property damage and/or serious damage and/or serious injury or death. Please read the installation, operating and maintenance instructions thoroughly before installing, operating or servicing this appliance.

SAFETY INFORMATION



DANGER

EXPLOSION—FIRE HAZARD

- Keep solid combustibles, such as building materials, paper, or cardboard a safe distance away from the heater as recommended by the instructions.
- Provide adequate clearances around air openings into the combustion chamber.
- Never use the heater in spaces which do or may contain volatile or airborne combustibles, or products such as gasoline, solvents, paint thinner, dust particles, or unknown chemicals.
- During operation, this appliance can be a source of ignition. Keep heater area clear and free from combustible materials, gasoline, paint thinner, cleaning solvents and other flammable vapours and liquids. Do not use heater in areas with high dust content. Minimum heater clearances from combustible materials: three (3) feet or 36 inches from top and two (2) feet or 24 inches from sides.
- Never store propane near high heat, open flames, pilot lights, direct sunlight, other ignition sources or where temperatures exceed 120 degrees F (49 degrees C).
- Propane vapours are heavier than air and can accumulate in low places. If you smell gas, leave the area immediately.
- Never install or remove a propane cylinder while the heater is lighted, near flame, pilot lights, or other ignition sources or while heater is hot to the touch.
- This heater is red hot during use and can ignite flammables too close to the burner. Keep flammables at least 3 feet (36 inches) from top and 2 feet (24 inches) from sides. Keep gasoline and other flammable liquid and vapours well away from heater.
- Store the propane cylinder outdoors in a well ventilated space out of the reach of children. Never store the propane cylinder in an enclosed area (house, garage, etc.). If heater is to be stored indoors, disconnect the propane cylinder for outdoor storage.

WARNING: FOR OUTDOOR USE ONLY

CARBON MONOXIDE HAZARD

This appliance can produce carbon monoxide which has no odor. Using it in an enclosed space can kill you. Never use this appliance in an enclosed space such as a camper, tent or home.

DANGER

CARBON MONOXIDE HAZARD

- This heater is a combustion appliance. All combustion appliances produce carbon monoxide (CO) during the combustion process. This product is designed to produce extremely minute, non-hazardous amounts of CO if used and maintained in accordance with all warnings and instructions. Do not block the air flow into or out of the heater.
- Carbon Monoxide (CO) poisoning produces flu-like symptoms, water eyes, headaches, dizziness, fatigue, and possibly death. You can't see and you can't smell it. It is an invisible killer. If these symptoms are present during operation of this product, get fresh air immediately!
- For outdoor use only.
- Never use inside house or other unventilated or enclosed areas.
- This heater consumes air (oxygen). Do not use in unventilated or enclosed areas to avoid endangering your life.

WARNING

BURN HAZARD

- Never leave heater unattended when hot or in use.
- Keep out of reach of children.

WARNING

WARNING indicates an imminently hazardous situation which, if not avoided, will result in death or serious injury.

WARNING

Certain materials or items, when stored under the heater, will be subject to radiant heat and could be seriously damaged.

CAUTION

SERVICE SAFETY

- Keep all connections and fittings clean. Make sure propane cylinder valve outlet is clean.
- During set up, check all connections and fittings or leaks using soapy water, never use a flame to check for leaks.
- Use as a heating appliance only. Never alter in any way to use with any device.

CAUTION

CAUTION indicates an imminently hazardous situation which, if not avoided, may result in minor or moderate personal injury, or property damage.

WARNING

- This product is fueled by propane gas. Propane gas is invisible, odorless, and flammable. An odorant is normally added to help detect leaks and can be described as having a "rotten egg" smell. The odorant can fade over time so leaking gas is not always detectable by smell alone.
- Propane gas is heavier than air and leaking propane will sink to the lowest level possible. It can ignite by ignition sources including matches, lighters, sparks or open flames of any kind many feet away from the original leak. Use only propane gas set up for vapor withdrawal.
- Store to use propane gas in compliance with local ordinances and codes or with ANSI/NFPA 58. Turn off propane when not in use.
- Alert children and adults to the hazards of high surface temperatures. Stay away from these surfaces to avoid burning skin or igniting clothing.
- Carefully supervise young children when in the vicinity of the heater.
- Do not hang clothing or any other flammable materials from the heater, or place near the heater.
- Replace any guard or protective device removed for servicing the appliance prior to placing back in service.
- Installation and repair should be done by a qualified service person. The heater should be inspected before use and annually be a qualified service person. More frequent cleaning may be required as necessary. It is imperative that the control compartment, burners, and circulating air passageway of the appliance be kept clean.

PACKAGE CONTENTS

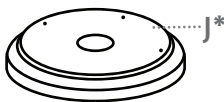
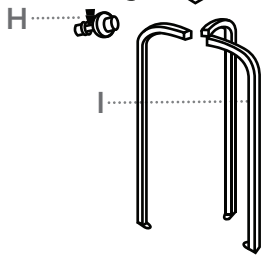
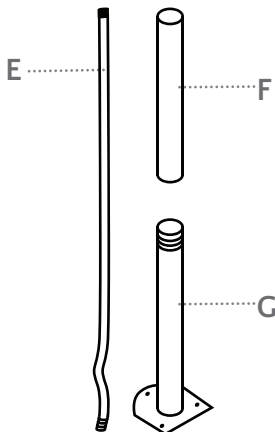
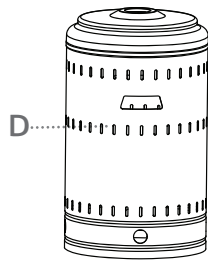
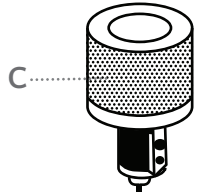
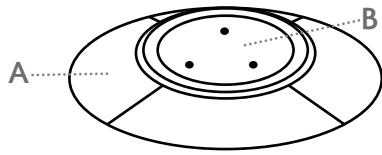

PART	DESCRIPTION	QUANTITY
A	Reflector Panel	4 packed in inner carton
B	Reflector Center Cap	1 packed under Base
C	Head Assembly	1 packed in 1 inner carton
D	Tank Housing	1
E	Gas Hose	1 attached to Head Assembly
F	Upper Post	1
G	Lower Post	1
H	Regulator	1 packed in inner carton
I	Post Supports	3 packed in 1 inner carton
J*	Base*	1
K	Wheel Assembly	1 packed in inner carton
L	Chain (secures LPG cylinder)	1 packed with post supports

*Some models come with an optional sandbox feature. See page 5 for details on sandbox assembly.



HARDWARE CONTENTS

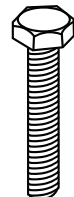

AA
Bolt
Qty: 6
(Step 3)

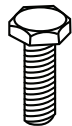

BB
Bolt
Qty: 5
(Step 1 & 2)



CC
Bolt w/Lock Washer
Qty: 4
(pre-assembled with burner)
(Step 7)

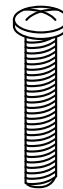

DD
Screw
Qty: 4
(pre-assembled in base/sandbox)



EE
Screw
Qty: 12
(Step 8)



FF
Flat Washer
Qty: 9
(Step 6 & 9)



GG
Flange Nut (GG)
Qty: 6
(Step 3)



HH
Nut
Qty: 4
(pre-assembled in base/sandbox)



II
Cap Nut
Qty: 12
(Step 8)



JJ
Wing Nut
Qty: 3
(Step 9)



KK
Reflector Stud
Qty: 3
(Step 6)

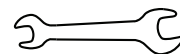

LL
Wrench (LL)
Qty: 1



PREPARATION

Before beginning assembly of this appliance, make sure all parts are present. Compare all parts with package contents list and hardware contents as listed on page 5 of this manual. If any part is missing or damaged, do not attempt to assemble this product. Contact customer service for replacement parts.

ESTIMATED ASSEMBLY TIME: 60 minutes

Tools Required for Assembly (NOT included):

- Phillips screwdriver w/medium blade
- Leak test solution (see page 11)

Optional **Sandbox: For models that come with a sandbox, the sandbox will be pre-assembled to the base. To fill the sandbox, remove the 4 **Screws (DD)** and **Nuts (HH)** that secure the base to the sandbox. Pull open the plastic cap on top of the sandbox and fill the sandbox with water or sand. Replace the plastic cap. Slide **Base** back over the sandbox and align the holes in the base with the holes in the sandbox. Insert **Screws (DD)** through the holes in the base and secure by tightening **Nuts (HH)** on ends of the bolts. You may find it easier to fill the sandbox prior to attaching wheels.*

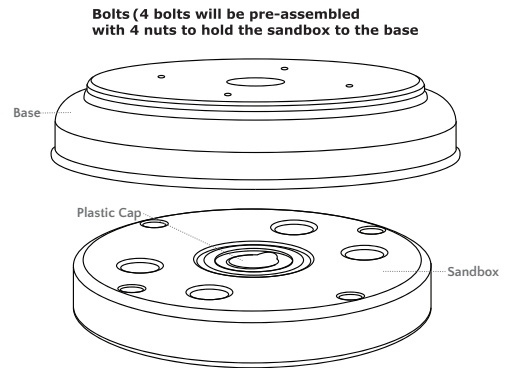

- 1 Attach **Wheel Assembly (K)** to **Base (J)**. Align holes in **Wheel Assembly** with corresponding holes in **Base**, and insert 2 **Bolts (BB)** through the holes and finger-tighten. Be sure that the **Wheel Assembly** is parallel to the **Base (J)** and tighten with the **Wrench.(LL)**



Hardware Used: 2 x Bolts (BB)
Wrench (LL)

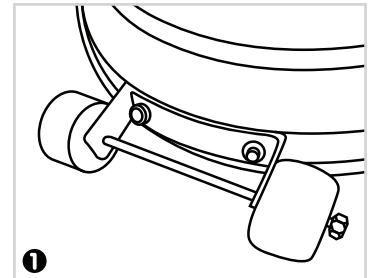

- 2 Attach the **Post Supports (I)** to the **Base (J)**. Align the holes in the bottom of each **Post Support** with the hole on the **Base**. Insert 1 **Bolt (BB)** through the hole in the support and into the **Base** and hand tighten. Repeat with the other 2 **Post Supports** and then tighten all bolts with the **Wrench**.



Hardware Used: 3 x Bolts (BB)

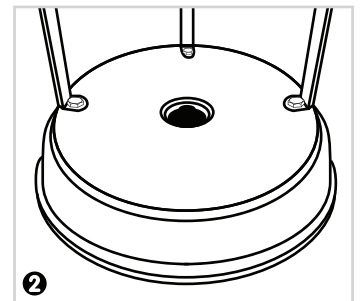
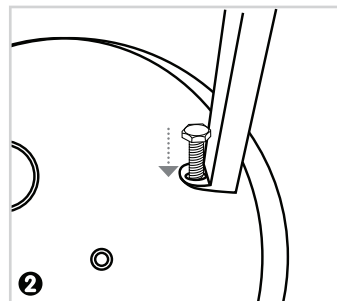

ASSEMBLY



3 Attach the **Lower Post** (G) to the **Post Supports** (I). Once you have tightened the bolts holding the **Post Supports** (I) to the **Base** (J), align the holes in the **Lower Post** (G) with the holes on the tops of the **Post Supports** and insert a **Bolt** (AA) through the hole in the **Post Supports** and insert a **Flange Nut** (GG). Repeat this in the 5 remaining holes (6 holes total—2 for each **Post Support** piece). Hand-tighten initially then tighten with the **Wrench** when all bolts have been inserted.

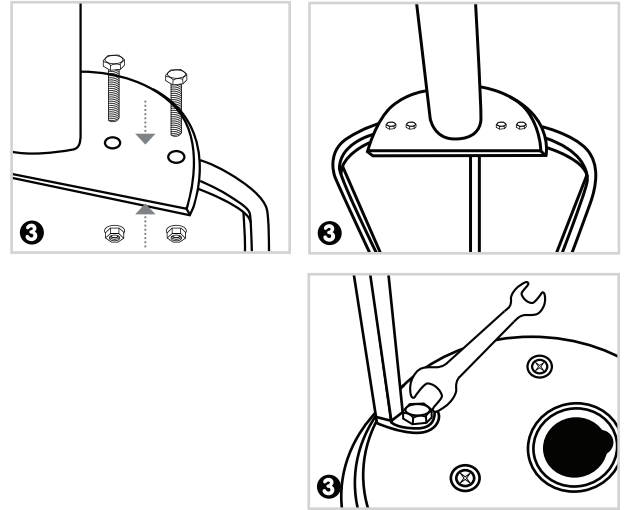

Hardware Used: 6 x Bolt (AA)
6 x Flange Nut (GG)

4 Attach **Upper Post** (F) to **Lower Post** (G) by screwing the two pieces of the post together.

5 Slide **Tank Housing** (D) over the assembled **Upper/Lower Posts** (F/G) and down over the **Post Supports** (I). Rest the **Tank Housing** on the **Base** (J).

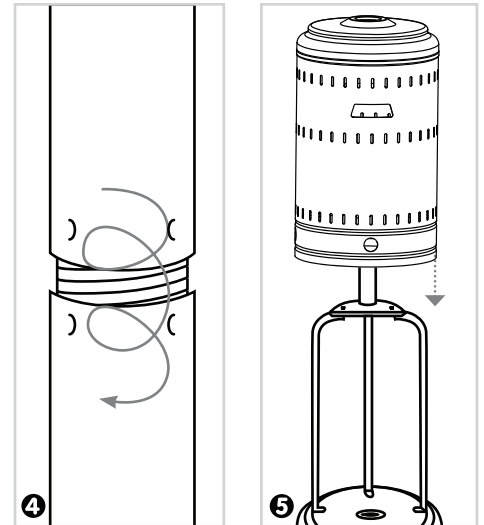

6 Attach **Reflector Studs** to the top of the **Head Assembly** (C). Insert 1 **Reflector Stud** (KK) through 1 **Flat Washer** and into the hole on the top of the **Head Assembly** (C). Tighten stud securely. Repeat with the other 2 **Reflector Studs**.



Hardware Used: 3 x Reflector Stud (KK)
3 x Flat Washer (FF)

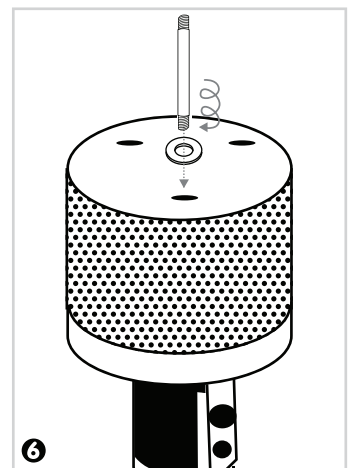

ASSEMBLY



7 Attach **Head Assembly (C)** to **Upper Post (F)**. Route **Gas Hose (E)** down into **Upper/lower Posts (F)/(G)** and align 4 small holes on the **Head Assembly (C)** with 4 Small holes in the **Upper Post (F)**. Insert the 4 **Bolts with Lock Washer (CC)** through the aligned 4 holes and tighten securely with the **Wrench (LL)**.



Hardware Used: 4 x Bolt w/Lock Washer
Wrench (LL)

8 Install Reflector. **NOTE: MAKE SURE TO REMOVE PROTECTIVE PLASTIC COVER ON REFLECTOR PIECES PRIOR TO ASSEMBLY!**

Assembly Tip: If necessary for proper alignment of reflector sections, loosen each screw prior to further assembly and retighten after sections are aligned.

Slide two **Reflector Panels (A)** together. Insert one **Screw (EE)**. Screw on **Cap Nut (II)** loosely.

Repeat with the other **Reflector Panels (A)**.

Slide **Reflector Center Cap (B)** onto assembled **Reflector Panels (A)**. Insert one **Screw (EE)** and screw on **Cap Nut (II)** loosely. Repeat with two more **Screws (EE)** and **Cap Nuts (II)** to complete reflector assembly. Fully tighten all screws and cap nuts.



Hardware Used: 12 x Screw (EE)
12 Cap Nut (II)

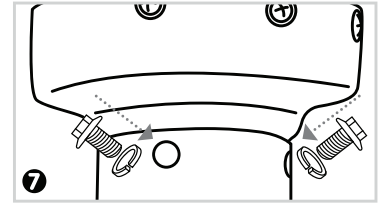
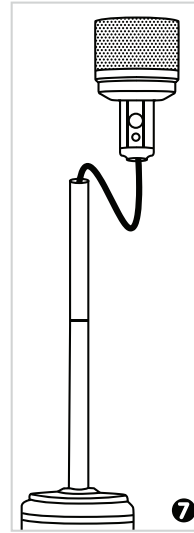

TIP: Route the gas hose down the upper post before assembling the upper and lower posts.

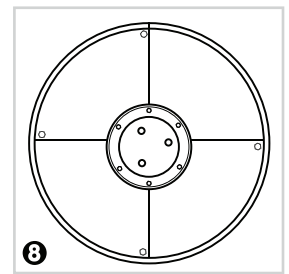
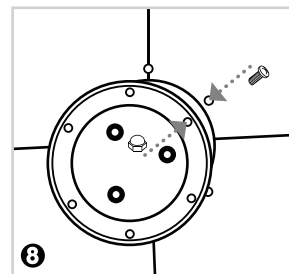
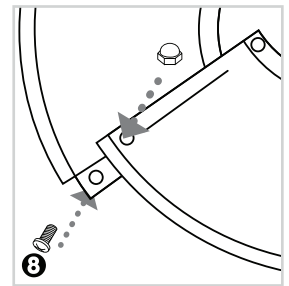
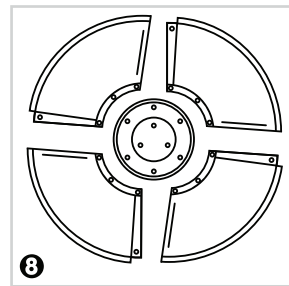

9 While supporting heater, tilt the **Head Assembly** (C) and slide **3 Flat Washers (FF)** over the **Reflector Studs**. Place the **Reflector Assembly** onto the **Reflector Studs** and slide **3 Flat Washers (FF)** over the **Reflector Studs** and onto the **Reflector Assembly**. Secure with **3 Wing Nuts (JJ)**. Once you have tightened the **Wing Nuts (JJ)**, return the heater to an upright position.

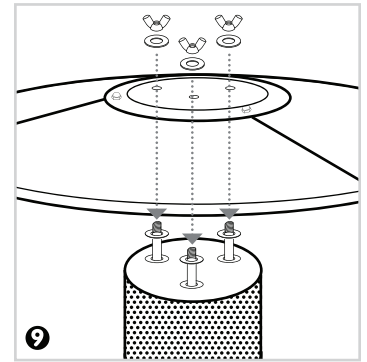
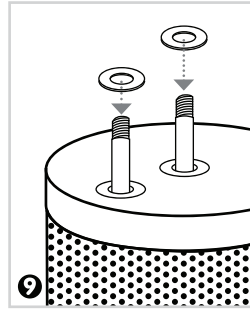

Hardware Used: 6 x Flat Washer (FF)
3 x Wing Nut (JJ)

10 Connect the hose and regulator to the LPG tank. The LPG tank is sold separately. Use a standard 9.07 kg 20 lb. propane tank *only*. Lift the **Tank Housing** (D) up and rest it on the top of the assembled **Post Supports** (I). Screw **Regulator** (H) onto **Gas Hose** (E). Do not cross thread. Attach the **Regulator** to the valve on the LPG tank and hand tighten securely. Place LPG tank onto base of heater. Secure the LPG tank by attaching the **Chain** (L) onto the post supports. Lower the **Tank Housing**.

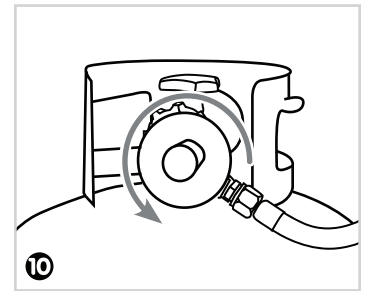
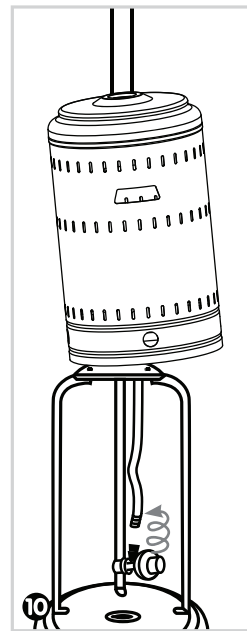

NOTE: Use this heater only with a propane vapour withdrawal supply system. See chapter 5 of the standard for storage and handling of liquefied petroleum gas, ANSI/NFPA 58. Your local library or fire department should have this book.

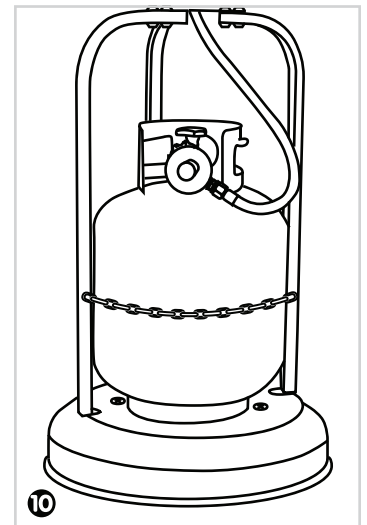

OPERATING INSTRUCTIONS



A minimum supply pressure of .5 psi is required for the purpose of input adjustment of propane gas. Storage of an appliance indoors is permissible only if the cylinder is disconnected and removed from the appliance. A cylinder must be stored outdoors in a well-ventilated area out of the reach of children. A disconnected cylinder must have dust caps tightly installed and must not be stored in a building, garage, or any other enclosed area. The minimum permissible gas supply pressure of 11 W.C. is required for purpose of hose adjustment. The minimum hourly of 17,500 BTU is required input rating for a heater for automatic operation rating less than full input rating.

The pressure regulator and hose assembly supplied with the appliance must be used.

The installation must conform with local codes, or in the absence of local codes, with national fuel gas code, ANSI Z223.1/NFPA54, natural gas and propane Installation Code, CSA B149.1, or propane storage and handling code, B149.2

A dented rusted or damaged propane cylinder may be hazardous and should be checked by your local cylinder supplier. Never use a propane cylinder with a damaged valve connection. The propane cylinder must be constructed and marked in accordance with the specifications or LPG tanks of the U.S. Department of Transportation (DOT) or the standard for cylinders, spheres and tubes for transportation of dangerous goods and commission, CAN/CSA-B339.

- Do not store a spare LP-gas cylinder under or near this appliance.
- Never fill the cylinder beyond 80 percent full.
- Place the dust cap on the cylinder valve outlet whenever the cylinder is not in use. Only install the type of dust cap on the cylinder valve that is provided with the cylinder valve. Other types of caps or plugs may result in leakage of propane.

- The cylinder must have a listed overfilling prevention device.
- The cylinder must have a connection device compatible with the connection for the appliance.
- The cylinder used must include a collar to protect the cylinder valve.
- Never connect an unregulated propane cylinder to the heater.

OPERATING INSTRUCTIONS



LEAK TEST

1. Make 2-3 oz. of leak test solution (one part liquid dish washing detergent and three parts water).
2. Apply several drops of solution where hose attaches to regulator.
3. Apply several drops of solution where regulator connects to cylinder.
4. Make sure all patio heater valves are OFF.
5. Turn cylinder valve ON.

WARNING

- Perform all leak tests outdoors.
- Extinguish all open flames
- NEVER leak test when smoking
- Do not use heater until all connections have been leak tested and show no signs of leakage.

IF BUBBLES APPEAR AT ANY CONNECTION, THERE IS A LEAK.

1. Turn cylinder valve OFF.
2. If leak is detected at hose/regulator connection, tighten connection and perform another leak test. If bubbles continue to appear, call our customer service hotline at **(800) 561-5550, 7:30 a.m. – 4 p.m., PST, Monday – Friday**.
3. If leak is detected at regulator/cylinder valve connection, disconnect, reconnect, and perform another leak test. If you continue to see bubbles after several attempts, cylinder valve is defective. Call our customer service hotline at **(800) 561-5550, 7:30 a.m. – 4 p.m., PST, Monday – Friday**

IF NO BUBBLES APPEAR AT ANY CONNECTION, THE CONNECTIONS ARE SECURE.

Note: *Whenever gas connections are loosened or removed, you must perform a complete leak test.*

WARNING: **FOR OUTDOOR USE ONLY**

CARBON MONOXIDE HAZARD

This appliance can produce carbon monoxide which has no odor. Using it in an enclosed space can kill you. Never use this appliance in an enclosed space such as a camper, tent or home.

Caution: *Do not attempt to operate this appliance until you have read and understand all Safety Information in this manual and all assembly is complete and leak tests have been performed.*

BEFORE TURNING GAS SUPPLY ON:

1. Your heater was designed and approved for **OUTDOOR use only**. Do NOT use it inside a building, garage, or any other enclosed area.
2. Make sure surrounding areas are free of combustible materials, gasoline, and other flammable vapours or liquids.
3. Ensure that there is no obstruction to air ventilation. Be sure all gas connections are tight and there are no leaks.
4. Be sure the cylinder cover is clear of debris. Be sure any component removed during assembly or servicing is replaced and fastened prior to starting.

BEFORE LIGHTING:

1. Heater should be thoroughly inspected before each use, and by a qualified service person at least annually. If re-lighting a hot heater, always wait at least 5 minutes.
2. Inspect the hose assembly for evidence of excessive abrasion, cuts, or wear. Suspected areas should be leak tested. If the hose leaks, it must be replaced prior to operation. Only use the replacement hose assembly specified by the manufacturer.

OPERATING INSTRUCTIONS



LIGHTING

NOTE: For initial start or after any cylinder change, hold the control knob in for 2 minutes to purge air from all gas lines before proceeding.

1. Turn the control knob to the "OFF" position.
2. Fully open the LPG tank valve.
3. Push in and turn the control knob to HI symbols.
4. Keep the control knob depressed and then push the RED igniter button simultaneously. Keep the igniter pushed in until the burner ignites. Keep the control knob fully depressed for an additional 30 seconds after the burner ignites, then release the control knob.
5. To increase the flame, turn the control knob clockwise towards HI. To decrease the flame, turn the control knob counter-clockwise towards LO.
6. To turn the appliance OFF, depress the control knob and turn clockwise to the OFF position.
7. Wait at least 5 minutes before attempting to re-light the heater.
8. Turn the LPG tank valve to OFF or closed. If you experience any ignition problems, please consult "Troubleshooting" on page 14.

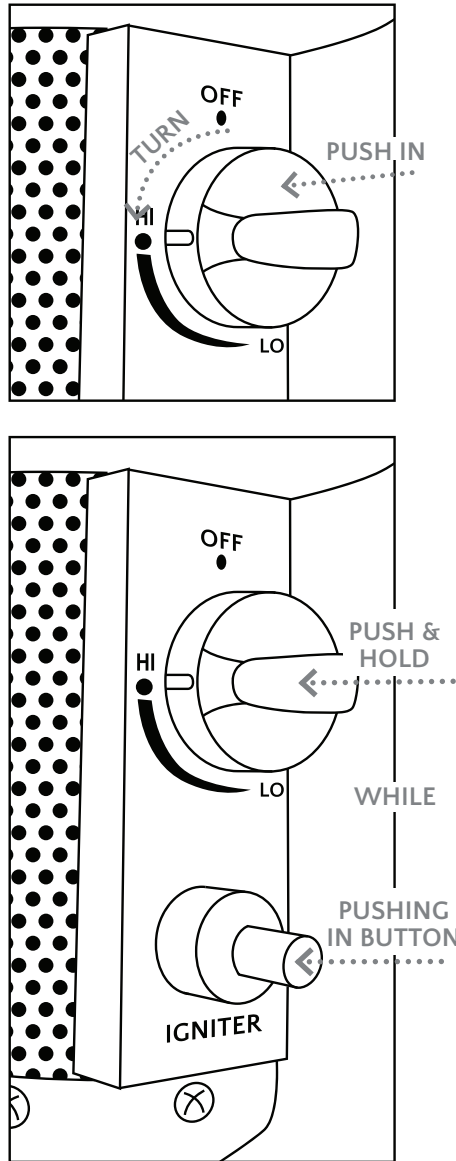

WARNING

FOR YOUR SAFETY
Be careful when attempting to manually ignite this heater. Holding in the control knob for more than 10 seconds before igniting the gas will cause a ball of flame upon ignition.

WHEN HEATER IS ON:

Emitter screen will become bright red due to intense heat. The color is more visible at night. Burner will display tongues of blue and yellow flames. These flames should not be yellow or produce thick black smoke, indicating an obstruction of airflow through the burners. The flame should be blue with straight yellow tops. If excessive yellow flame is detected, turn off heater and consult "Troubleshooting" on page 14.

RE-LIGHTING:

Note: For your safety, the control knob cannot be turned OFF without first depressing the control knob and then rotating to OFF.

1. Turn control knob to OFF.
2. Wait at least 5 minutes to allow gas to dissipate before re-lighting.
3. Repeat the "Lighting" steps listed above.

Caution: Avoid inhaling fumes emitted from the heater's first use. Both smoke and odour from the burning of oils used in the manufacturing will appear. Both smoke and odour will dissipate after approximately 30 minutes. The heater should NOT produce thick black smoke.

*If you experience any ignition problems, please consult "Troubleshooting" on page 15. **Caution:***

Avoid inhaling fumes emitted from the heater's first use. Smoke and odour from the burning of oils used in the manufacturing will appear. Both smoke and odour will dissipate after approximately 30 minutes. The heater should NOT produce thick black smoke.

NOTE: This heater uses an electronic ignition and requires the installation of 1 - AAA battery (not included). The battery must be installed by unscrewing the IGNITER BUTTON.

Operating Instructions



OPERATION CHECKLIST:

For a safe and pleasurable heating experience, perform this check before each use:

BEFORE OPERATING:

- I am familiar with entire owner's manual and understand all precautions noted.
- All components are properly assembled, intact and operable.
- No alterations have been made.
- All gas connections are secure and do not leak.
- Wind velocity is below 10 mph / 36 kmh.
- Heater is for use outdoors (outside any enclosure).
- There is adequate fresh air ventilation.
- Heater is away from gasoline or other flammable liquids or vapors.
- Heater is away from windows, air intake openings, sprinklers and other water sources.
- Heater is at least 36 in./91.4 cm on top and at least 24 in./61cm on sides from combustible materials.
- Heater is on a hard and level surface.
- There are no signs of spider or insect nests in heater orifices.
- All burner passages are clear.
- All air circulation passages are clear.
- Clothing or other protective material should not be hung from the heater, or placed on or near the heater.
- Any guard or other protective device removed for servicing the heater must be replaced prior to operating the heater.
- Installation and repair should be done by a qualified service person. The heater should be inspected before each use and at least annually by a qualified service person.

OPERATION INFORMATION AND SAFETY:

- Unit will operate at reduced efficiency below 40 degrees F / 4.4 degrees C..
- Children and adults should be alerted to the hazards of high surface temperatures and should stay away to avoid burns or clothing ignition.
- Young children should be carefully supervised when they are in the area of the heater.
- More frequent cleaning may be required as necessary. It is imperative that control compartment burner and circulating air passageways of the heater be kept clean and free of debris and/or spider or insect nests.



WARNING

FOR YOUR SAFETY
Heater will be hot after use. Handle with extreme care.

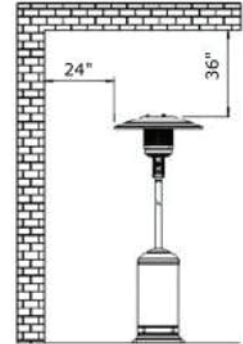

SHUT DOWN:

1. Turn control knob clockwise to OFF while depressing the knob. (Normally, burner will make a slight popping noise when extinguished).
2. Turn cylinder valve clockwise to OFF and disconnect regulator when heater is not in use.

NOTE: After use, some discoloration of the emitter screen is normal.



AFTER OPERATION:

1. Gas control knob is in OFF position.
2. Gas tank valve is OFF.
3. Disconnect gas line.
4. Heater is stored upright in a secure location.

CARE AND MAINTENANCE



To enjoy years of outstanding performance from your heater, make sure you perform the following maintenance activities on a regular basis:

KEEP EXTERIOR SURFACES CLEAN.

1. Use soapy water for cleaning. Never use flammable or corrosive cleaning agents.
2. While cleaning your unit, be sure to keep the area around the burner and control compartment dry at all times. Do not submerge the control valve assembly. If the gas control is submerged in water, do NOT use it. It must be replaced.
3. Air flow must be unobstructed. Keep controls, burner, and circulating air passageways clean. Signs of possible blockage include:
 - Gas odor with extreme yellow tipping of flame
 - Heater does NOT reach the desired temperature.
 - Heater glow is excessively uneven.
 - Heater makes popping noise.
 - Spiders and insects can nest in burner or orifices. This dangerous condition can damage heater and render it unsafe for use. Clean burner holes by using a heavy-duty pipe cleaner. Compressed air may help clear away smaller particles.
 - Carbon deposits may create a fire hazard. Clean dome and burner screen with warm soapy water if any carbon deposits develop.

Note: *In a salt-air environment (such as near an ocean), corrosion occurs more quickly than normal. Frequently check for corroded areas and repair them promptly.*



TIP FOR STAINLESS-STEEL MODELS:

Use high-quality automobile wax to help maintain the appearance of your heater. Apply to exterior surfaces from the post down. DO NOT apply to emitter screen or domes.

WARNING

FOR YOUR SAFETY

- Do NOT touch or move heater for at least 45 minutes after use.
- Reflecto is hot to the touch.
- Allow reflecto to cool before touching.

STORAGE:

Between uses:

- Turn control knob OFF.
- Disconnect LP source.
- Store heater upright in an area sheltered from direct contact with inclement weather (such as rain, sleet, hail, snow, dust and debris).
- If desired, cover heater to protect exterior surfaces and to help prevent build-up in air passages. Never leave LPG tank exposed to direct sunlight or excessive heat.

Note: Wait until heater is cool before covering.

SERVICE:

Only a qualified service person should repair gas passages and associated components.

Caution: *Always allow heater to cool before attempting service.*

PROBLEM	POSSIBLE CAUSE	CORRECTIVE ACTION
Main burner will not light	Gas valve may be off	Turn gas valve ON
	Fuel tank may be empty	Refill LPG tank
	Orifice blocked	Clean or replace orifice
	Air in supply system	Purge air from lines. Open gas lines and depress control knob for 2-3 minutes.
	Loose connection	Check all fittings
	Igniter fails	Use stick lighter to manually light
	Gas pressure low with valve open full	Replace cylinder or regulator
	New cylinder or 1st ignition	Purge air from lines
	Cylinder valve on, no gas flow	Replace hose/regulator assembly
Low burner flame	Pressure is low	Replace LPG tank
	Tank is low on fuel	Fill LPG tank
	Gas hose is kinked	Check and straighten or replace
Burner unit	Carbon on reflector and emitter screen	Clean components as needed
	Thick black smoke	Blockage in burner assembly—thoroughly clean burner



Questions, problems, missing parts?

Before returning to your retailer, our exceptional customer service is available.

Call us toll-free at **(800) 561-5550 Monday – Friday 7:30 a.m. – 4 p.m., PST**, email us at **customer@jrhome.com**.

IMPORTANT

For questions, concerns or problems with our product please email our customer service department:

customercare@jrhome.com

DATED PROOF OF PURCHASE REQUIRED FOR WARRANTY SERVICE

Si vous éprouvez des difficultés ou si vous avez des questions ou des préoccupations, prière de faire parvenir un courriel à notre service à la clientèle

customercare@jrhome.com

UNE PREUVE D'ACHAT DATÉE EST REQUISE POUR SE PRÉVALOIR DE LA GARANTIE.

WARRANTY

This product is inspected, tested and carefully packaged to minimize the chance of damage during shipment. If a part (excluding light bulbs, glass and fuses*) within one year from the date of purchase proves to be defective in material or fabrication under normal use, the part will be repaired or replaced. The Company's obligation under the warranty is to replace or repair defective parts at our discretion. Any expenses or damage resulting from the installation, removal or transportation of the product will be the responsibility of the owner and are not covered by this warranty. The owner assumes all other risks arising from the use or misuse of the product. The warranty will be void if the product damage or failure is deemed by the Company to be caused by accident, alteration, misuse, abuse, incorrect installation or removal, or connection to an incorrect power source by the owner. The Company neither assumes, nor authorizes any person or entity to assume for it any obligation or liability associated with its products. Light bulbs and fuses are not covered under this warranty. If you have any questions regarding the warranty or service, please contact us at **customercare@jrhome.com**.

Customer Service :

JR Home Products

Unit 306 - 19100 Airport Way, Pitt Meadows, BC V3Y 0E2

Toll Free : 1-800-561-5550

E-mail : **customercare@jrhome.com**

AVERTISSEMENT

Ce produit a été soigneusement inspecté, testé et emballé afin de minimiser les risques de dommages durant le transport. Si l'une des pièces (à l'exception des verres, des ampoules électriques et des fusibles*) s'avère défectueuse au niveau de sa fabrication ou de ses matériaux dans l'année qui suit la date de l'achat suite à une utilisation normale, la pièce sera réparée ou remplacée. La compagnie est tenue de réparer ou remplacer les pièces défectueuses à sa discrétion, en vertu de la garantie. Tous frais ou dommage résultant de l'installation, du démantèlement ou du transport du produit demeurent la responsabilité du client et n'est pas couvert par cette garantie. Le client assume tout autre risque résultant de l'utilisation correcte ou fautive du produit. La garantie devient nulle si la compagnie détermine que le dommage ou le mauvais fonctionnement est causé par un accident, une modification, une mauvaise utilisation, un abus, une mauvaise installation ou un mauvais démantèlement ou un branchement à une source électrique inadéquate de la part du client. La compagnie n'est pas responsable et n'autorise quiconque, personne ou entité légale, à accepter de responsabilité ou obligation en son nom, en rapport avec ses produits. * Les ampoules électriques et les fusibles ne sont pas couverts par cette garantie. Pour toute question au sujet de la garantie ou du service, contacter le service à la clientèle à : **customercare@jrhome.com**.

Service à la clientèle:

JR Home Products

Unit 306 - 19100 Airport Way, Pitt Meadows BC V3Y 0E2 Numéro

sans frais: 1-800-561-5550

Courriel: **customercare@jrhome.com**

You MUST register your product within 30 days of purchase to receive warranty service.

Registration can be completed online at www.jrhome.com or by mailing this form.

Vous DEVEZ enregistrer votre produit dans les 30 jours suivant l'achat pour bénéficier du service de garantie.

L'enregistrement sera complet une fois que vous aurez posté ce formulaire ou que vous serez inscrit en ligne.



Warranty Registration Information Form / Formulaire d'enregistrement de la garantie

Name / Nom : _____

Street / Adresse : _____

City / Ville : _____

Province / Province : _____

Postal Code / Code postal : _____

Daytime Phone # / No téléphone jour : _____

Evening Phone # / No téléphone soir : _____

E-Mail Address / Courriel : _____

Product/Produit : _____

Place of Purchase / Lieu de l'achat : _____

Date of Purchase / Date de l'achat : _____

Model # / No de modèle : _____

Serial # / Numéro de série : _____

You MUST register your product to receive warranty service.

For warranty service, contact J&R Home Products at the address, phone numbers listed below within 30 days of purchase. Be sure to have your sales receipt and original date of purchase. All warranty service will be coordinated by J&R Home Products service center.

Vous DEVEZ enregistrer votre produit pour vous prévaloir de la garantie.

Afin de faire valoir la garantie, communiquez avec J&R Home Products à l'adresse et aux numéros indiqués ci-dessous dans les 30 jours suivant la date d'achat. Ayez en main votre reçu et la date d'achat. Toutes les demandes liées aux garanties seront traitées par le centre de service de J&R Home Products.